

Terabit™

Industrial 2.5" SATA 6.0Gbp.s Solid State Drive

Data Sheet

Terabit Technology

Revision History

Version	Date	Changes	Note
V001	2015-06-28	Release	
	2015-10-20	2TB added	MLC Flash

Terabit Technology

Contents

1. Product Features.....4

2. Overview.....5

3. Interface.....5

4. Physical Dimension.....6

5. PIN Description.....7

 5.1 PIN Location.....7

 5.2 Signal Description.....7

6. Power Consumption.....8

7. Product Reliability.....8

 7.1. Wear Leveling.....9

 7.2 ECC.....9

 7.3 Over-Provision.....9

 7.4 Bad-block Management.....9

 7.5 S.M.A.R.T Function.....9

 7.6 TRIM Function.....9

8. Performance.....10

9. Cache.....10

10. Thermal Sensor.....10

11. Certifications.....11

12. Ordering Information.....12

13. Contact Information.....12

1. Product Features

Interface	7PIN+15PIN
Form Factor	2.5" SATAIII 6.0Gbps
Dimension	100.2 x 69.80 x 7.0/9.0 ±0.2(mm)
Capacity	NAND MLC: 32GB~2048GB NAND SLC: 16GB~512GB
Performance	Read up to 545MB/s Write up to 500MB/s
Power Supply	D/C 5.0V± 5%
Operating Temperature	Standard: 0~+70°C Industrial: -20~+70°C Extended: -40~+85°C
Weight	<90g
Storage Temperature	-55~+95°C
Shock	Non-operating 1500G peak, 0.5ms Operating 50G peak, 11ms
Vibration	Jet (Random) Vibration, 10-2000Hz, 16.4G(X, Y, Z)
Burn-in Test	72 Hours
Max. Power Consumption	Sequential Reading 1.58W Sequential Writing 3.95W Idle 0.3W
Maximum Ripple	100mV, 0~30MHz
MTBF	2,000,000 Hours
Features	<ul style="list-style-type: none"> - Enhanced endurance by dynamic/static wear-leveling - Support dynamic power management - Support S.M.A.R.T function - Automatic Bad-block Management - Support TRIM and NCQ (Native Command Queuing) Command - Support BCH ECC 66bits/1024bytes - Conformal Coating optional - Over-Provision function - Tantalum Capacitors optional
Data Retention	@25°C: 10 years
Certification	CE/FCC/RoHS

2. Overview

Terabit 2.5" SATAIII SSD fully consists of semiconductor devices using original NAND Flash and Industrial Controller which provide high reliability and high performance for data storage. Terabit 2.5" SATAIII SSD has standard 22PIN interfaces, fully conform to the same mechanical and mounting requirements as standard rotating disk drives. This series of products are designed for premium industrial applications that require both strong reliability and high capacity such as Industrial Computer, Rugged Computer, Industrial Systems, Industrial Server, Embedded Systems, Workstations, RAID and Defense. With up to 2048GB capacity on NAND MLC Flash and 512GB on SLC Flash, Terabit 2.5" SATAIII SSD totally goes through a variety of proofing tests such as Shock Test, Vibration Test, Burn-in Test, and Twisting Test. Well proved under -40~+85°C wide temperature and equipped with Power Failure Protect and Over Load Protect, this series of products can work smoothly under severe environments.

3. Interface

Terabit 2.5" SATAIII Solid State Drive complies SATA 6.0Gbps Standard.
Compatible for SATA 1.5Gbps, 3Gbps standard.

4. Physical Dimension

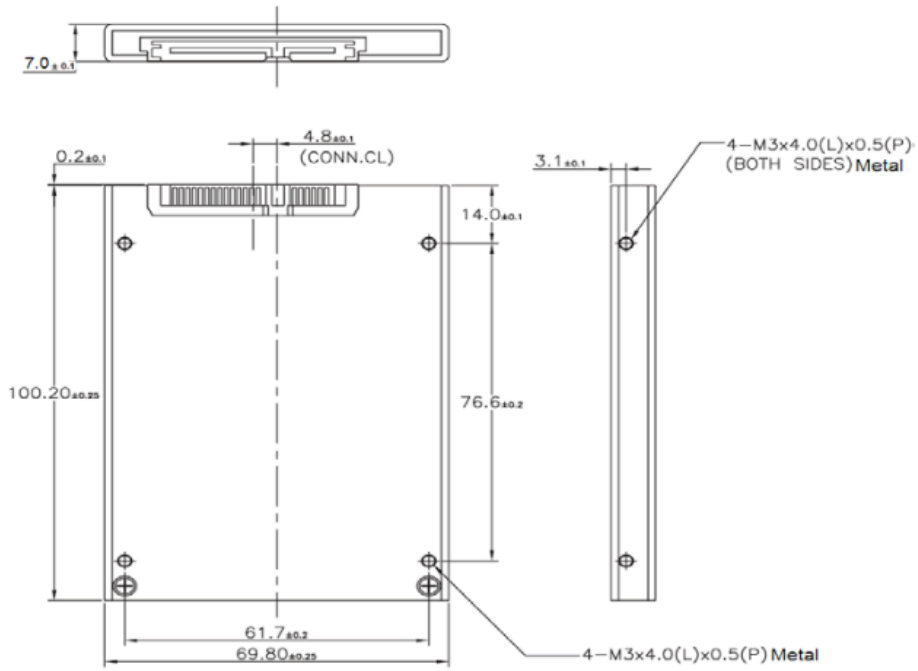

Parameter	Value	Unit
Length	100.2	mm
Width	69.80	mm
Height	7.0	mm

- All of the values are ±0.2mm
- 9.0mm as default

5. PIN Description

5.1 PIN Location

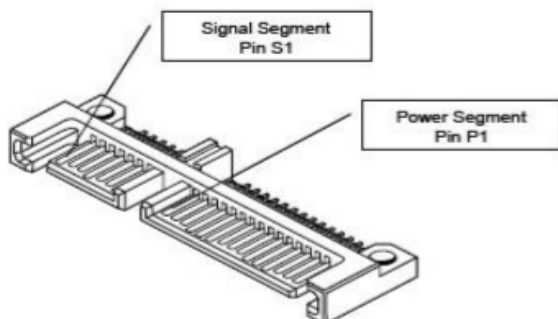

5.2 Signal Description

PIN#	PIN Name	PIN Definition
Signal		
S1	GND	
S2	A+	Differential signal pair A
S3	A -	Differential signal pair A
S4	GND	
S5	B-	Differential signal pair B
S6	B+	Differential signal pair B
S7	GND	
Power		
P1	3.3V	Not Used (3.3V)
P2	3.3V	Not Used (3.3V)
P3	DEVSLP	
P4	GND	
P5	GND	
P6	GND	
P7	5V	5V pre-charge
P8	5V	5V power
P9	5V	5V power
P10	GND	
P11	Reserved	
P12	GND	
P13	12V	12V pre-charge
P14	12V	Not Used (12V)
P15	12V	Not Used (12V)

6. Power Consumption

Capacity	Idle	Read	Write	Unit
32GB	0.27	1.15	2.82	W
64GB	0.27	1.28	3.03	W
128GB	0.28	1.44	3.18	W
256GB	0.30	1.47	3.20	W
512GB	0.30	1.50	3.42	W
1024GB	0.30	1.53	3.70	W
2048GB	0.30	1.58	3.95	W

7. Product Reliability

NAND MLC Flash:

Capacity	Endurance Total Bytes Written	Data Retention	MTBF	Warranty
32GB	Up to 90TB	@25°C >10 Years	2 Million Hours	3 Years Limited
64GB	Up to 180TB			
128GB	Up to 360TB			
256GB	Up to 720TB			
512GB	Up to 1500TB			
1024GB	Up to 3000TB			
2048GB	Up to 6000TB			

NAND SLC Flash:

Capacity	Endurance Total Bytes Written	Data Retention	MTBF	Warranty
16GB	Up to 1250TB	@25°C >10 Years	2 Million Hours	5 Years Limited
32GB	Up to 2500TB			
64GB	Up to 5000TB			
128GB	Up to 10000TB			
256GB	Up to 20000TB			
512GB	Up to 40000TB			

*Total Bytes Written= 【(Flash P/E cycle) x (number of bits in drive)】 /WAI
WAI=1.428704724

7.1 Wear-Leveling

NAND flash devices can only undergo a limited number of program/erase cycles, and in most cases, the flash media are not used evenly. If some areas get updated more frequently than others, the lifetime of the device would be reduced significantly. Thus, Wear Leveling is applied to extend the lifespan of NAND Flash by evenly distributing write and erase cycles across the media. Terabit 2.5" SATAIII SSD support both static and dynamic wear-leveling technology. These two algorithms guarantee each block of flash memory at same level of erase cycles to improve lifetime limitation of NAND based storage.

7.2 ECC

ECC (Error Correction Code): Enhanced configurable BCH ECC engine. Terabit 2.5" Industrial SATAIII SSD implements the BCH ECC Algorithm, which is one of the most powerful ECC algorithms in the industry. This algorithm can correct up to 12 random bit errors in each 512 bytes.

7.3 Over-Provision

Over Provisioning refers to the inclusion of extra NAND capacity in a SSD, which is not visible and cannot be used by users. With Over Provisioning, the performance and IOPS (Input/Output Operations per Second) are improved by providing the controller additional space to manage P/E cycles, which enhances the reliability and endurance as well. Moreover, the write amplification of the SSD becomes lower when the controller writes data to the flash.

7.4 Bad-block Management

Terabit implements an efficient bad block management algorithm into the SSD to detect factory produced bad blocks as well as those that develop over the lifetime of the device. This process is completely transparent to the user through the use of S.M.A.R.T. command tools, i.e., the user will not be aware of the existence of the bad blocks during operation.

7.5 S.M.A.R.T Function

S.M.A.R.T stands for Self-Monitoring, Analysis and Reporting Technology. This technology enables the PC to predict the future failure of hard disk drives. Through the S.M.A.R.T. system, Terabit 2.5" SATAIII SSD incorporates a suite of advanced diagnostics that monitor the internal operation of the drive and provide an early warning for many types of potential problems. When a potential problem is detected, the SSD can be repaired or replaced before any data is lost or damaged.

7.6 TRIM Function

Terabit Solid State Drive equips built-in TRIM function, it helps collect and clean data garbage when the system in an idle situation, which keeps the system in a high performance status even after long-term using.

8. Performance

Capacity	*Sequential Read	*Sequential Write	IOPS Read (max)	IOPS Write (max)
16GB	220MB/s	98MB/s	42000	37000
32GB	291MB/s	140MB/s	45000	40000
64GB	392MB/s	177MB/s	47000	42000
128GB	485MB/s	420MB/s	52000	46000
256GB	500MB/s	445MB/s	55000	51000
512GB	515MB/s	505MB/s	57000	54000
1024GB	530MB/s	510MB/s	58000	57000
2048GB	545MB/s	530MB/s	60000	60000

*Based on SM2246EN+Micron 16nm NAND MLC Flash

Performance will vary due to different platforms and software

9. Cache

Cache	DDR2	DDR3	Capacity
Support	/	Yes	/

10. Thermal Sensor

Thermal monitors are devices for measuring temperature, and can be found in SSDs in order to issue warnings when SSDs go beyond a certain temperature. The higher temperature the thermal monitor detects, the more power the SSD consumes, causing the SSD to get aging quickly. Hence, the processing speed of a SSD should be under control to prevent temperature from exceeding a certain range. Meanwhile, the SSD can achieve power savings.

11. Certifications



EN 55022:2010

EN: 55024:2010

EN 61000-3-2:2013

EN 61000-3-3:2014

47 CFR, Part2, Part15, CISPR PUB.22

With reference to RoHS Directive 2011/65/EU recasting 2002/95/EC

Terabit Technology

12. Ordering information

Series	*Model Name	Capacity	Flash	Housing
2.5" SATAIII SSD Industrial	T25S3XTMLC-032G	32GB	NAND MLC	9mm
	T25S3XTMLC-064G	64GB	NAND MLC	9mm
	T25S3XTMLC-128G	128GB	NAND MLC	9mm
	T25S3XTMLC-256G	256GB	NAND MLC	9mm
	T25S3XTMLC-512G	512GB	NAND MLC	9mm
	T25S3XTMLC-1024G	1024GB	NAND MLC	9mm
	T25S3XTMLC-2048G	2048GB	NAND MLC	9mm

Series	Model Name*	Capacity	Flash	Housing
2.5" SATAIII SSD Industrial	T25S3XTSLC-016G	16GB	NAND SLC	9mm
	T25S3XTSLC-032G	32GB	NAND SLC	9mm
	T25S3XTSLC-064G	64GB	NAND SLC	9mm
	T25S3XTSLC-128G	128GB	NAND SLC	9mm
	T25S3XTSLC-256G	256GB	NAND SLC	9mm
	T25S3XTSLC-512G	512GB	NAND SLC	9mm

* XT refers to temperature range, ST refers to standard temperature, CT refers to industrial temperature, KT refers to extended temperature.

* Housing 7.0mm optional

13. Contact Information

Shanghai Terabit Technology Co., Ltd

Telephone: +86.21.34303488

Fax: +86.21.34303488

Email: sales@terabitsd.com

Website: www.terabitsys.com

Address: #513, No.38 Building, Wanke VMO, No. 2049 Pujin Road, Pujiang Town, Minhang District, Shanghai, 201112 P.R. China